



Pumps for hygienic use

The complete line





Everything you need, everywhere you need it

Alfa Laval provides the widest range of hygienic products and accessories in the world. Designed for superior safety, efficiency and cleanliness, they ensure careful product handling in the food, dairy, beverage, biotech, pharmaceutical and personal care industries.

Our pumps, heat exchangers, valves, automation, tank equipment and installation material offer solutions for all process stages – and almost certainly the solution you need.

This brochure introduces our quality pumps for hygienic applications. For complete technical details and product specification, please contact your local Alfa Laval supplier or visit us at

www.alfalaval.com



Gentle product treatment

Our centrifugal pumps are renowned for their ability to move products gently and efficiently. The integrity of your product is assured, regardless whether you choose a premium or standard-duty model.

Advanced hygienic design

With emphasis on features such as optimized internal geometry and profiled o-rings, our centrifugal pumps are suitable for Cleaning In Place (CIP) and offer exceptional levels of hygiene. All have been tested in accordance with EHEDG requirements and many are authorized to carry the 3A symbol.

Advanced seal design

Our LKH premium pumps (models 5-60) and our SolidC standard-duty pumps share the same mechanical shaft seal, which simplifies maintenance and spare parts inventory. Combined with the quick and easy front-loading design, this reduces maintenance costs, increases uptime and reduces the cost of ownership.

Easy seal conversion

The external design of our centrifugal pumps, as well as the seal's construction, is designed to make seal conversion as fast and as simple as possible. Our premium LKH pumps can be converted from single to flushed or double-mechanical seals, while our standard-duty SolidC pumps can be converted from single to flushed shaft seals.

Centrifugal pumps

Alfa Laval's centrifugal pumps are built to perform in all areas – from process quality to overall energy efficiency. In addition to gentle product handling and a wide range of hygienic features, they provide a long and trouble-free service life that ensures low cost of ownership.

Our centrifugal pump series can be divided into two categories, premium and standard-duty.

The first category comprises our various LKH series, which handle even specialized needs such as multistage, high-pressure, self-priming and high-purity applications. The second focuses on cost efficiency and includes our value-optimized SolidC pump series.

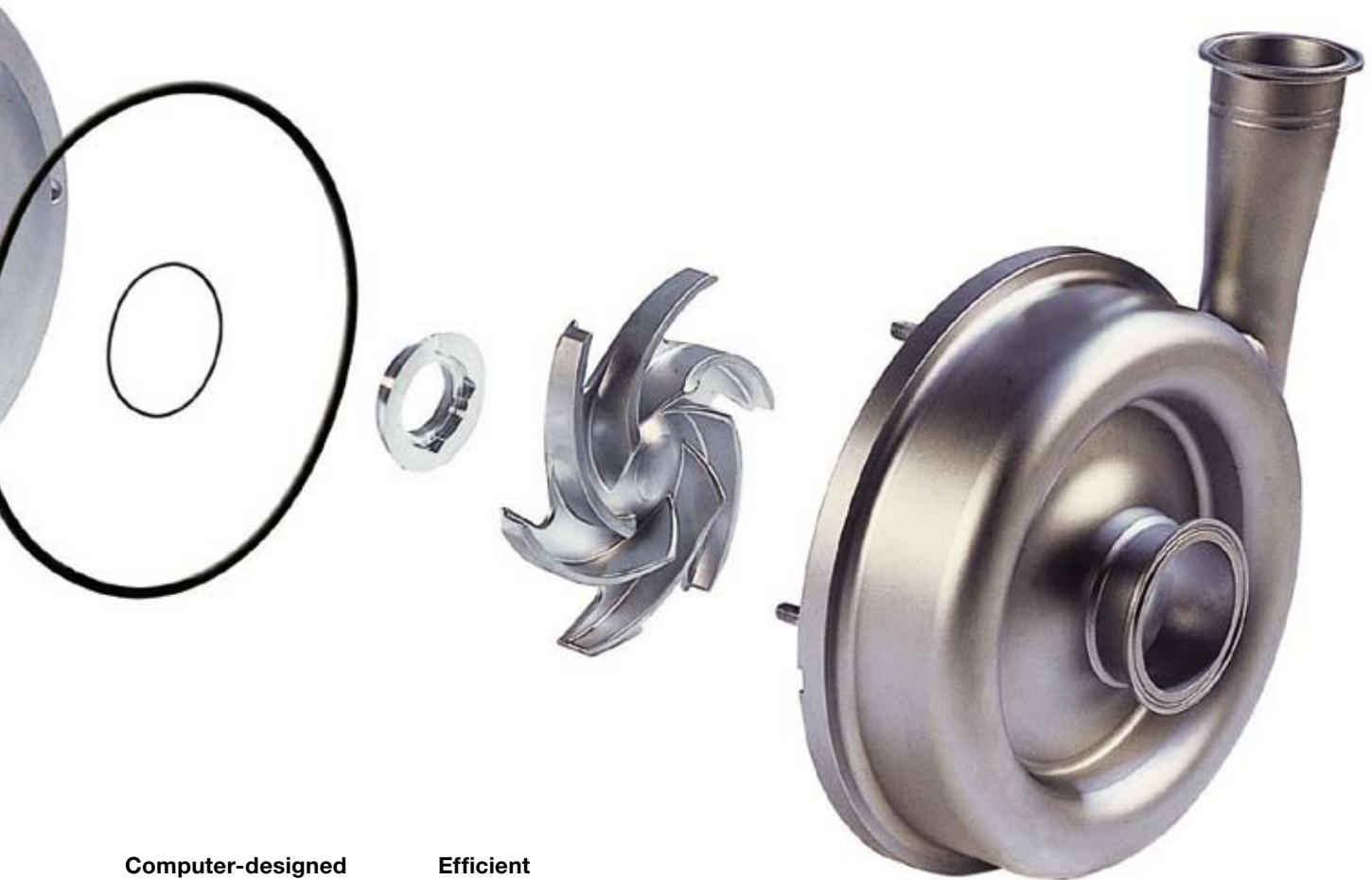

Computer-designed impellers

Our centrifugal pump impellers are computer-designed and hydraulically balanced for optimum performance. Both the impellers and their retaining screws (optional) are smooth, which keeps them from accumulating product and makes cleaning more effective.

Efficient performance

Our centrifugal pumps consume less power and exhibit low noise levels. In addition, they minimize the risk of cavitation thanks to low NPSH requirements.

Premium pumps

Quiet but rugged, Alfa Laval's LKH series of centrifugal pumps are the ultimate solution for gentle and efficient product handling. Through a combination of enlarged inlets and advanced impeller design, they offer an unobstructed product flow and very low NPSH requirements.

LKH pumps are designed for Cleaning In Place (CIP). Polished models are USDA approved and

exceed 3A standards, so you can always be sure of the greatest possible hygiene.

LKH pumps are available in capacities of up to 440 m³/h and pressures of up to 190 m (19 bar), with different versions are available for specific applications

LKHSP

Pumps in the LKHSP series are self-priming, which means they can be used to pump products containing air or gas. This makes them ideal as return pumps in CIP systems, as well as for emptying tanks. LKHSP pumps feature a tank, a non-return valve (normally closed) on the inlet side, a tee and a non-return valve (normally open) on the bypass line.



LKH-UltraPure

LKH-UltraPure pumps are high-purity models that meet specifications for water-for-injection (WFI) and other demanding applications. Authorized to carry the 3A symbol, they are suitable for both CIP and Sterilization In Place (SIP), as well as manual cleaning. LKH-UltraPure pumps are also available with a 0.5 µm (150 grit) finish, 3.1 certification and a flushed seal kit.



LKHP-High Pressure

Pumps in the LKHP-High Pressure series feature a reinforced pump casing and backplate, as well as high-pressure internal seals and multiple heavy-duty studs. This lets them handle inlet pressures as high as 40 bar (600 PSI), making them ideal for nanofiltration and reverse osmosis filtration. Their seals can be removed in a matter of seconds, without removal of the back plate.



LKH-High Multistage

Designed to 3A standards and available in two-, three- or four-stage models, LKH-Multistage pumps save space and energy by replacing up to three booster pumps in a line. Used primarily in high-pressure applications with low capacity, they withstand system pressures up to 40 bar (600 PSI) and deliver boost pressures up to 19 bar (275 Psi). This makes them suitable for both reverse osmosis and ultrafiltration.

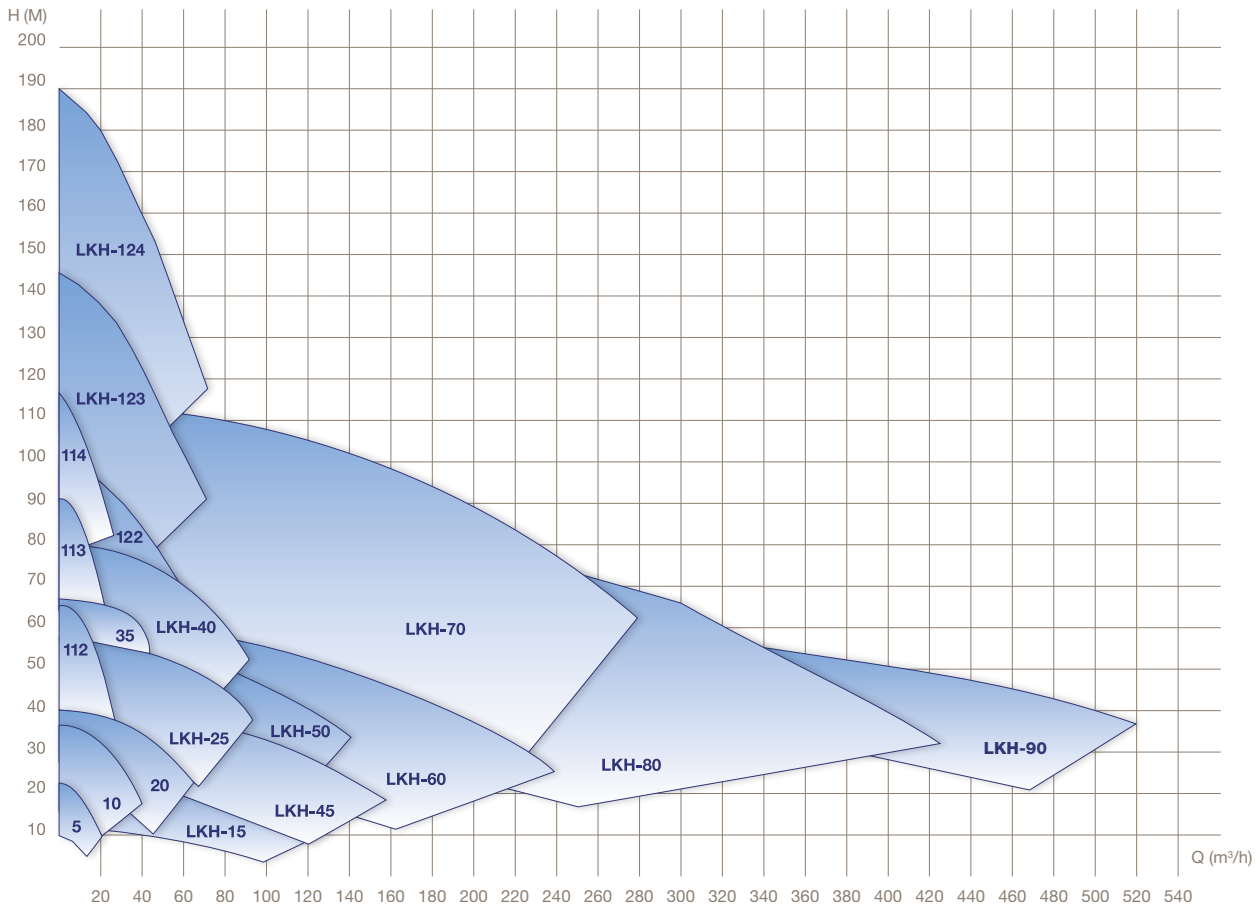

LKH performance LKH pumps are available for capacities up to 440 m³/h and pressures up to 190 m (19 bar/275 psi).

Standard-duty pumps

Alfa Laval's standard-duty centrifugal pumps are designed to offer high value for money. In addition to gentle product handling and efficient operation, they offer high reliability and possibilities for swift and easy maintenance.

The highlight of our standard-duty pumps is the SolidC series, which combines a practical, cost-effective design with certain characteristics of our premium LKH centrifugal pumps



SolidC

The SolidC pump series is a reliable and cost-effective solution for simple transport duties up to 85 m³/h. It utilizes the same mechanical shaft seal found in our LKH series, which is front-loaded and easily replaced without removing the backplate. SolidC pumps are available in four sizes and comply with 3A, CE and EHEDG requirements.

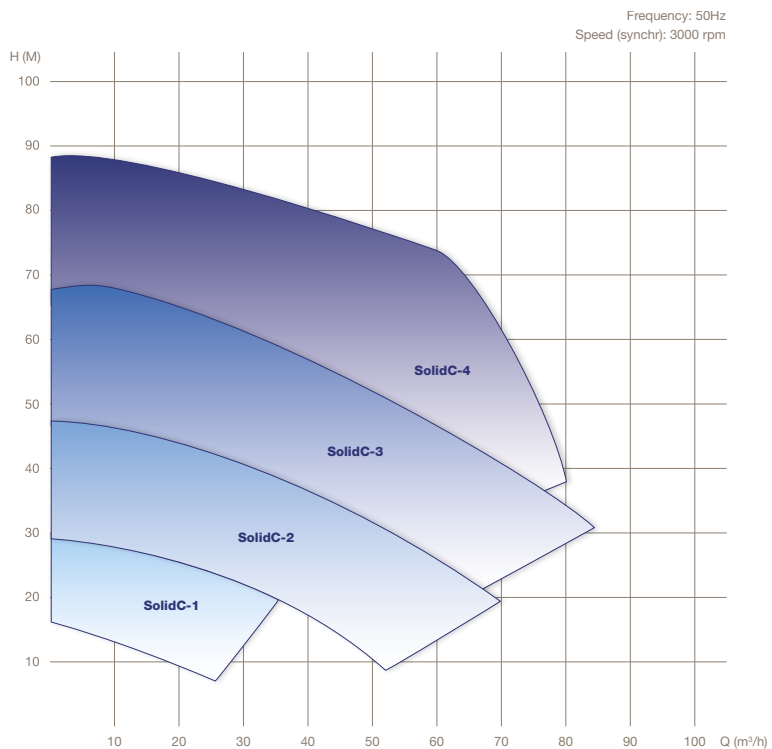

SolidC performance SolidC is a reliable, cost-effective centrifugal pump for standard duties up to 85 m³/h.

GM Centrifugal Pump

The GM centrifugal pump series is a value-focused alternative for industries in which acid-resistant steel is required. GM pumps are specifically designed to handle simple applications at low capacities, which makes them a cost-effective solution.



Liquid ring pumps

Liquid ring pumps are an ideal solution when gases are contained in the process medium. Because the pumps are self-priming when the casing is half filled with fluid, they are capable of pumping from a suction line that is partly filled with air or other gases.

Alfa Laval's liquid ring pumps are specially developed for use in food, chemical and pharmaceutical industries, where they are often used as return pumps in Cleaning-In-Place (CIP) systems.



MR-Liquid Ring

Through its simplicity of design, the MR series of liquid ring pumps combines high efficiency with low maintenance. The impeller is cast with straight, radial vanes and is fixed onto a pump shaft within a covered pump casing. A standard electric motor is used to drive the MR pump head.

Rotary lobe pumps

Suitable for low, medium and high-viscosity media, Alfa Laval rotary lobe pumps are the fulfilment of more than 50 years of commitment to rotary lobe pump technology. Their gentle pumping action and reliable performance are the result of continuous development, which is based upon years of experience and carried out at our advanced production and R&D facilities.

Our rotary lobe pump portfolio comprises three ranges: SX, SRU and OptiLobe. Each of these is robustly constructed and offers Alfa Laval's high standards of quality and reliability, and each is positioned for a different type of demand. Collectively, they provide operating economy and high flexibility of use.



Gentle, hygienic design

With their high-precision rotors and low-shear operation, our rotary lobe pumps ensure the gentle movement of delicate products. The pumps offer a number of features that maximize cleanability, and their construction provides compliance with the world's leading hygienic standards.

Modular pump design

Our rotary lobe pumps feature a modular construction. This design feature increases flexibility and reduces spare parts inventory.

Universal mounting

To allow high flexibility when fitting the pump into a production line, all of our rotary lobe pumps can be mounted in either a vertical or horizontal port position (with the exception of the larger SX models).

Improved drainability

All of our rotary lobe pumps can be drained easily when mounted in vertical port position. In the case of our OptiLobe and SX pumps, cusps are retained in vertical configurations for greater efficiency.



Easy seal retrofit

The seals of our rotary lobe pumps are designed for quick and simple up-grading. Our broad range of seals includes many seal types and configurations, which can be tailored to your need and application.

Robust gearbox construction

Our rotary lobe pumps are fitted with a robust gearbox incorporating heavy-duty taper roller bearings and torque locking assemblies that allow for easy maintenance and high reliability. The pump rotors are driven by a high-precision involute spline drive.

CIP and SIP

Our rotary lobe pumps are suitable for use in both Cleaning-in-Place (CIP) and Sterilization-in-Place (SIP) applications.

Standards and approvals

All of our rotary lobe pumps are compliant with the EHEDG, 3A and FDA hygienic standards. In addition, our SX and SRU pumps have ATEX approval for use in explosive environments.

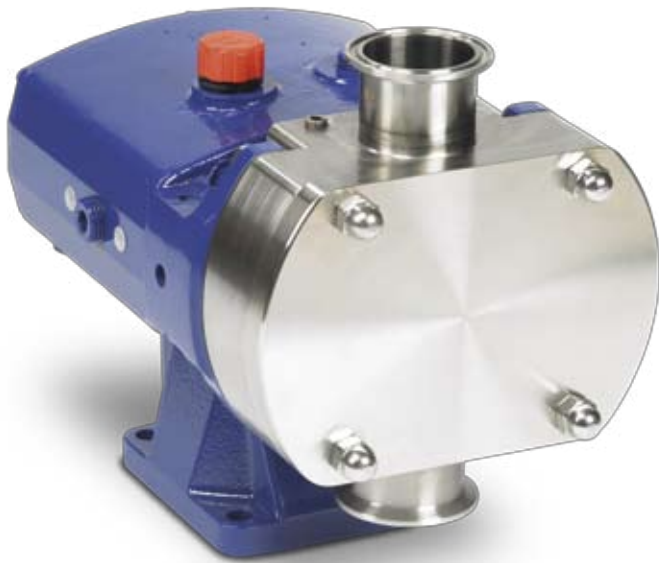

SX

The SX is Alfa Laval's premium rotary lobe pump, designed for use in sensitive and ultra-clean applications. With their optimized pump head geometry and multi-lobe rotors, SX pumps ensure low-shear operation with minimum pulsation. This makes them the best choice for maintaining the integrity of delicate products.

SX pumps feature front-loading mechanical seals, as well as a profiled gasket system for the highest level of hygienic sealing. Pump hygiene is further improved by a low-profile rotor nut, which enhances the pump cleanability.

Higher surface finishes up to 0.5 Ra are available, as well as electro-polishing and 3.1 material traceability.



SRU

The SRU is Alfa Laval's core rotary lobe pump. In addition to handling the widest range of temperatures and pressures, SRU pumps offer the most extensive options in our rotary lobe pump portfolio. Their heavy-duty construction and unparalleled flexibility make them an engineered solution for the most demanding applications.

Among the many SRU options are saddles and jackets for heating/cooling the pump head and an integrated pressure relief valve and rectangular inlet for pumping high viscosity fluids. A wide selection of standard seal options is available, together with proprietary seals to suit most applications.

There are tri-lobe and bi-lobe rotors to choose from, which can be manufactured from various materials. Bi-lobe alloy rotors can be used for closer tolerances and higher efficiencies on low-viscosity products.

Higher surface finishes up to 0.5 Ra are also available, as well as electro-polishing.



OptiLobe

The OptiLobe is Alfa Laval's rotary lobe pump intended for general applications. Available in an optimized range with fewer options, OptiLobe pumps combine cost-effective simplicity with Alfa Laval quality and reliability.

OptiLobe pumps feature a paint-free design with front-loading seals and tri-lobe rotors. They are the latest example of Alfa Laval's leadership in innovative design and advanced manufacturing processes.



Solutions for your application...

Alfa Laval has hygienic pumps for every need, however large or small. Each one is an efficient and reliable product, designed to carry out its tasks effectively for years on end.

Drawing on experience from a broad range of industries and an even broader range of pumping applications, we can provide solutions for specialized as well as general demands. From low viscosities to high, we have both the knowledge and the products to create a solution.



Food and beverages

Alfa Laval pumps facilitate the gentle and careful processing of foods and beverages. Their total hygiene ensures product quality, while their efficient operation provides maximum cost efficiency.



Dairy

Alfa Laval pumps supply the impeccable quality needed in working with dairy products. Their thorough, durable engineering ensures that raw materials are handled with the highest standards of reliability and hygiene.



Brewing

With hygienic design and gentle handling, Alfa Laval pumps provide breweries with effective ways of transferring brewery products. All brewing stages are catered for, no matter what the type of brew or the brewing process used.



Biopharm

Alfa Laval pumps meet the stringent hygienic requirements of the biotech and pharmaceutical industries. Several of our pump ranges are specifically designed for and used in ultra-hygienic applications.

...and service to match

Alfa Laval's service mission is to bring you expertise, enabling you to achieve the highest level of performance. With Alfa Laval as your performance partner, you have a trusted local provider for all your needs – and one that offers all the advantages of a global organization.

Alfa Laval takes care of your basic requirements, such as delivering replacement parts to your door and keeping your equipment in top condition. But as your local consultants, we also share our process and equipment knowledge with you. Our expertise in separation, heat transfer and fluid handling technologies can all be put to good use in optimizing your plant.

Alfa Laval spare parts

Investing in quality brings you long-term savings. That's why investing in genuine spare parts pays off.

With Alfa Laval spare parts, you know exactly what you get: quality spare parts that are the product of extensive research and development. Our spare parts are all precisely engineered and manufactured to endure the specific application for which they were designed.

Moreover, Alfa Laval spare parts are rigorously tested in our materials laboratory under actual operating conditions. So you can count not only on the perfect fit, but also on optimal performance.

Plan your budget and downtime

To get the best possible return on your investment, you must be able to rely on your equipment. Scheduled preventive maintenance – with Alfa Laval maintenance programmes, performance agreements and genuine Alfa Laval spare parts – allows you to plan both your operating budget and your downtime.



Alfa Laval in brief

Alfa Laval is a leading global provider of specialized products and engineered solutions.

Our equipment, systems and services are dedicated to helping customers optimize the performance of their processes. Time and time again.

We help our customers to heat, cool, separate and transport products such as oil, water, chemicals, beverages, food-stuffs, starch and pharmaceuticals.

Our worldwide organization works closely with customers in almost 100 countries to help them stay ahead.

How to contact Alfa Laval

Up-to-date Alfa Laval contact details for all countries are always available on our website at www.alfalaval.com

Alfa Laval is a trademark registered and owned by Alfa Laval Corporate AB.

