



# SERIE C Mouvex Technology

## Eccentric disc pump

### Seal free design

- Seal free means leak free. Designed without mechanical seal, packing or magnets, the C series eliminates leakage and reduces maintenance time.

### CIP & SIP abilities

- The stainless steel version is designed to be flushed and cleaned in place without disassembling.

### Sanitary & Food applicable

- The stainless steel models are ideal for sanitary applications, carry 3A approval certification and are designed per EHEDG recommendations.



### Chemical applicable

- The range of C pumps are in conformity with ATEX certification.



# SERIE C - Mouvex Technology - Eccentric disc pump

## ◆ Low pulsation effect

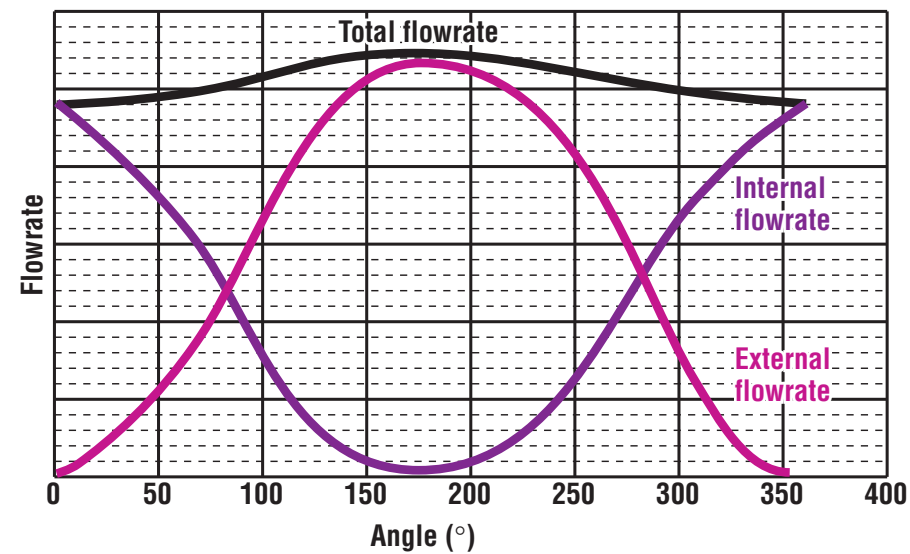

## ● Mouvex Technology

Disc face to the cylinder (front view)

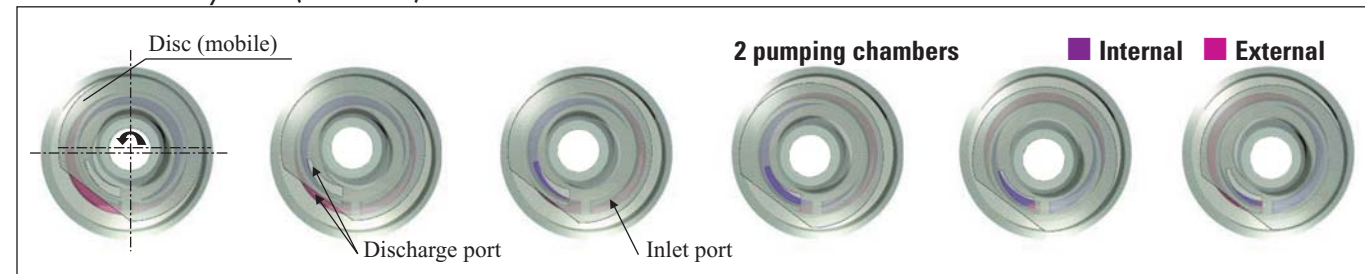

Disc face to the cylinder (cross section)



## ● Low shearing

### Displacement of the disc in the cylinder

- The disc has an eccentric motion (driven by an eccentric shaft).
- Each point of the disc has the same linear speed.
- We get a circular translation.
- The mouvex technology allows a flowrate with low linear speed.

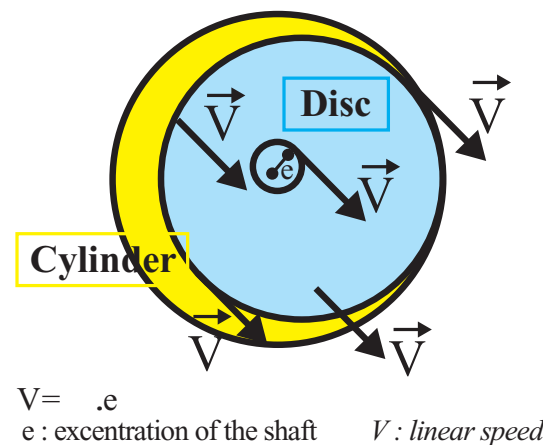

$$V = \omega \cdot e$$

$e$  : excentration of the shaft      $V$  : linear speed

## ● Main advantages

- Self-priming with strong suction power
- Ability to clear the pipes
- Ability to run dry
- Low shear
- Maintenance of the delivery/pressure performance over time due to automatic disc/cylinder adjustment
- Outstanding volumetric efficiency
- Pumped product constantly renewed
- Ability to pump low and high viscosity products
- Output not affected by viscosity variation
- Low linear speed

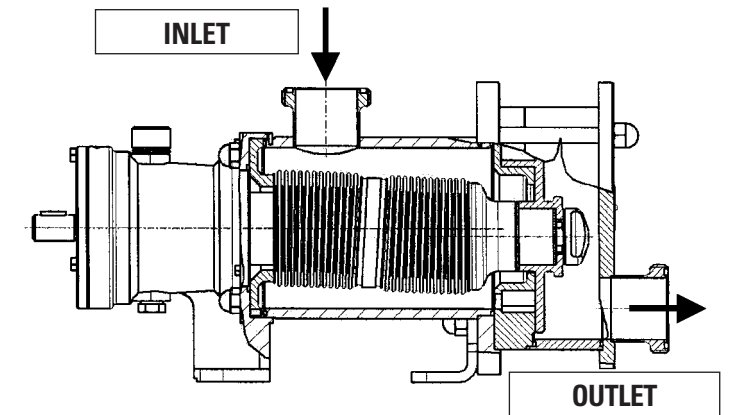

C SERIES (cross section)

## ● Pump without mechanical seal (seal free design)

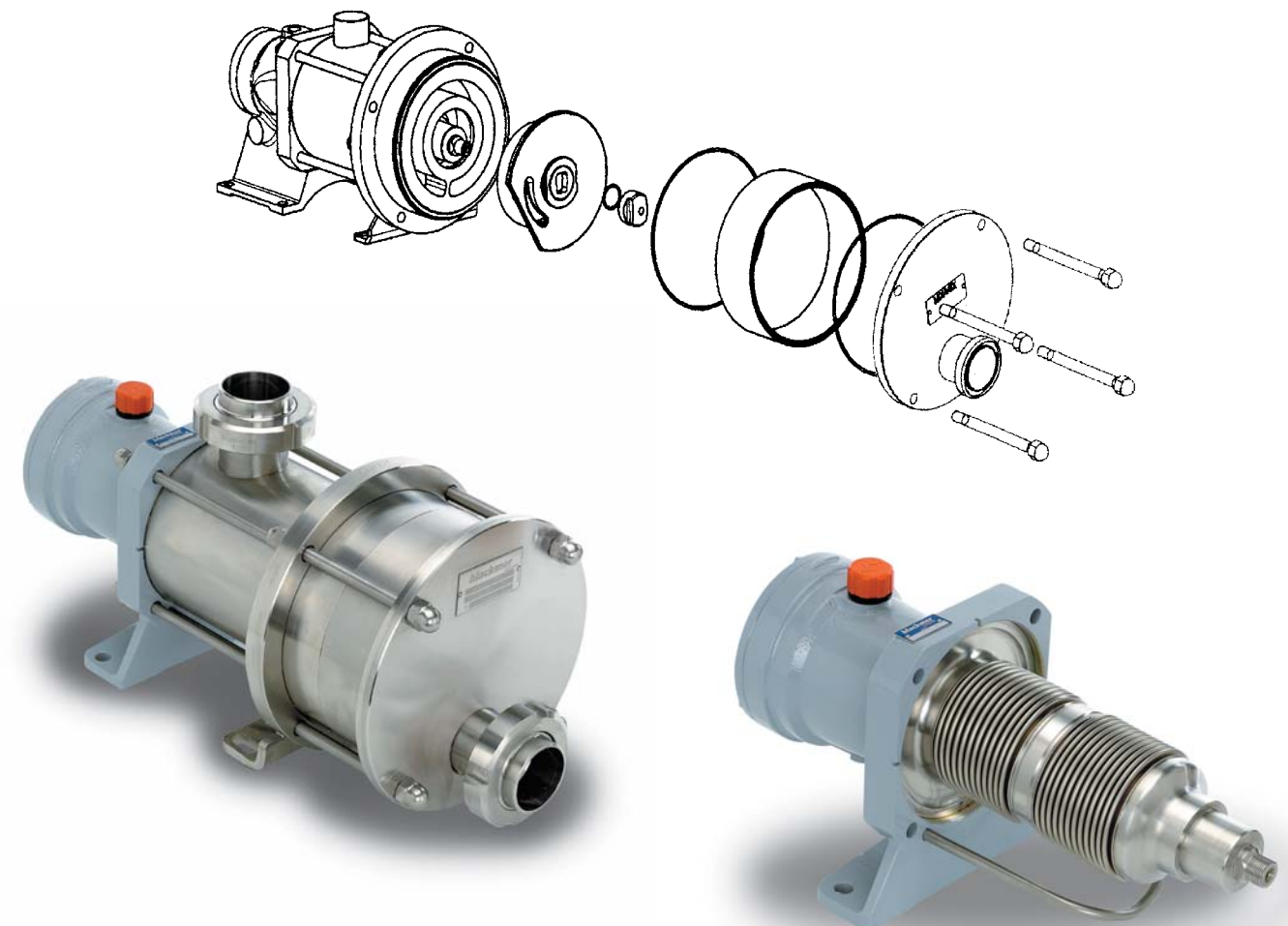

# SERIE C - Mouvex Technology - Eccentric disc pump

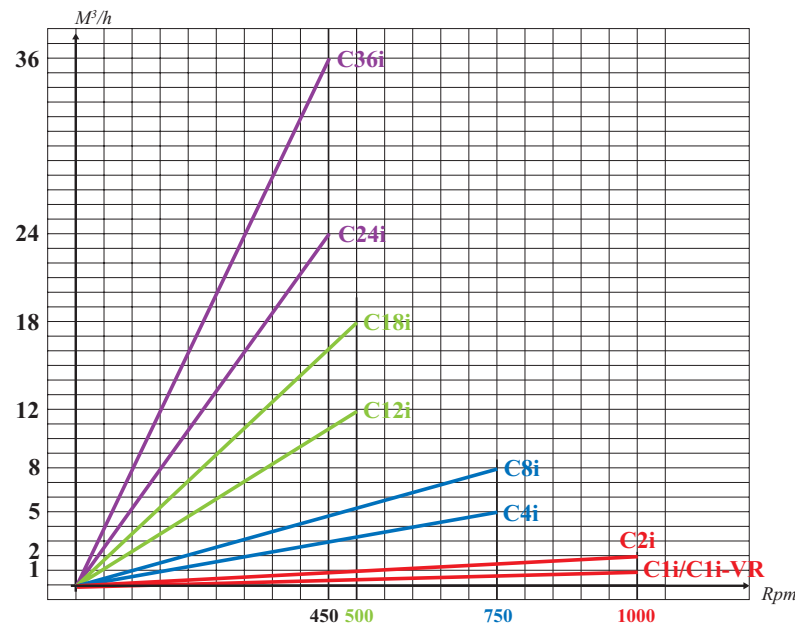

BELLOWS : 316 Ti Stainless steel  
 DISC : "actéon" Stainless steel  
 CYLINDER : 316 L Stainless steel  
 BODYCASE : 316 L Stainless steel

SEAL : FDA Viton (L gasket)  
 Viton O'Ring  
 Encapsulated teflon  
 Téflon (L gasket)

PORT : SMS, DIN, CLAMP, IDF...  
 Flanges PN16, PN20

## Stainless steel construction :

C Series Pump	C1i (C1i-VR)	C2i (C2i-VR)	C4i	C8i	C12i	C18i	C24i	C36i	C4i-HT	C8i-HT	C12i-HT	C18i-HT
Displacements (liters)	0,016	0,033	0,108	0,178	0,411	0,617	0,95	1,42	0,108	0,178	0,411	0,617
Max. outputs (m³/h)	1	2	5	8	12	18	24	36	5	8	12	18
Max. T° (°C) continuous	100	100	100	100	100	100	100	100	150	150	150	150
Max. pressure (bar)	9	9	9	5	9	6	9	6	9	6	9	6
Max. speed (Rpm)	1000	1000	750	750	500	500	450	450	750	750	500	500
Particle passage* (mm³)	2	2	5	5	15	15	20	20	5	5	15	15
Opening size (Suct/Disch) (mm)	40	40	50	50	60	60	70	70	50	50	60	60
CIP/SIP (120° C)	YES (only with SS construction)											

\*no hard particles

## Options



High temperature



Heating jacket

## Stainless steel construction :

C Series Pump	C1i (C1i-VR)	C2i (C2i-VR)	C4i	C8i	C12i	C18i	C24i	C36i
A	19	19	20	20	35	35	38	38
B	6	6	6	6	10	10	10	10
C	162	162	233	233	310,5	310,5	345,5	345,5
D	236	249,5	257	274	428	447,5	533,5	561,5
E	53	53	62	62	96,5	96,5	121	121
F	196	196	228	228	337	337	395	395
G	105	105	120	120	175	175	224	224
H	105,5	105,5	99	99	146,5	146,5	215	215
J					101	101	128,5	128,5
K	95,5	95,5	150	150	157	157	237,5	237,5
L	131,5	131,5	167	167	238	238	325,5	325,5
M	110	110	152	152	220	220	210	210
N	4	4	4	4	6	6	6	6
P	10	10	14	14	18	18	18	18
Q							280	280

Port (mm)	40	40	50	50	65	65	80	80
Weight (kg)	21 (24)	22 (25)	38	41	115	120	185	200

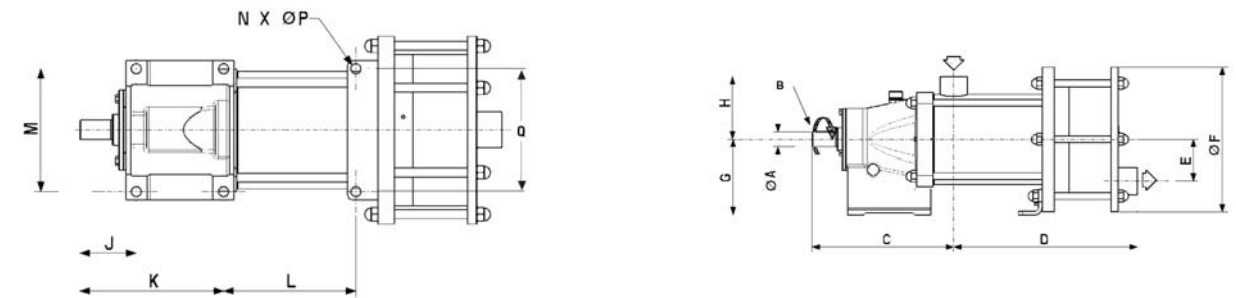

Mobile unit



Shroud

# SERIE C - Mouvex Technology - Eccentric disc pump

## ◆ Stainless steel construction

Cleaning recommendations

	C1/C2	C4/C8	C12/C18	C24/C36
CIP outputs required (m³/h) (maximum value)	10	10	30/35	40/45
Do we have to set up a bypass				
CIP outputs (m³/h)	15	YES	NO	NO
	20	YES	NO	NO
	25	YES	YES	NO
	30	YES	YES	NO
	35	YES	YES	NO
40	YES	YES	NO	NO

### Setting without Bypass

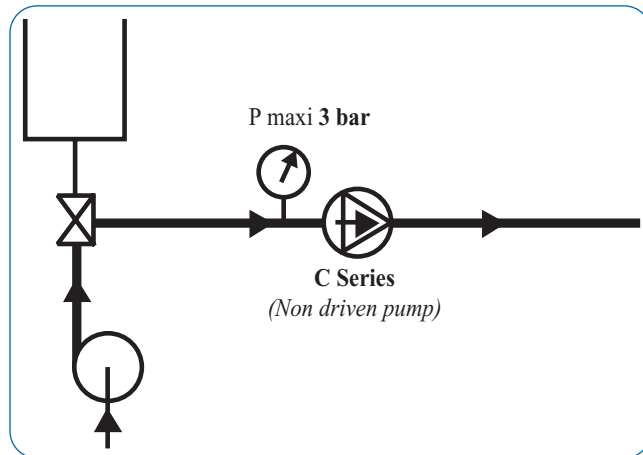

### Setting with Bypass

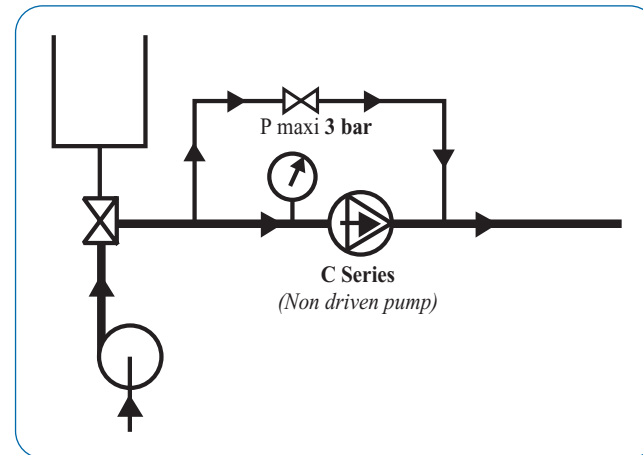

### Cleaning in 2 steps (pump & installation)

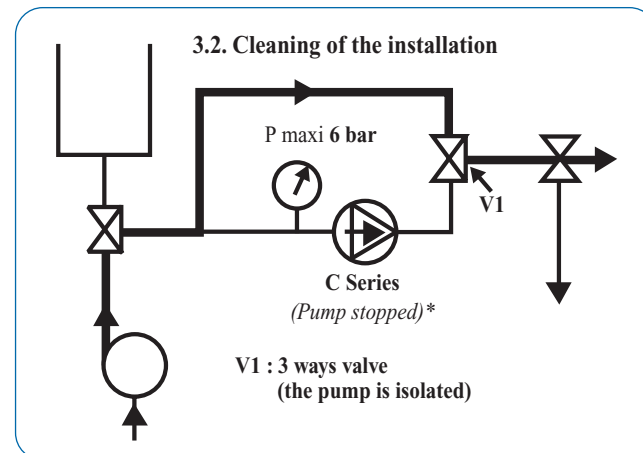
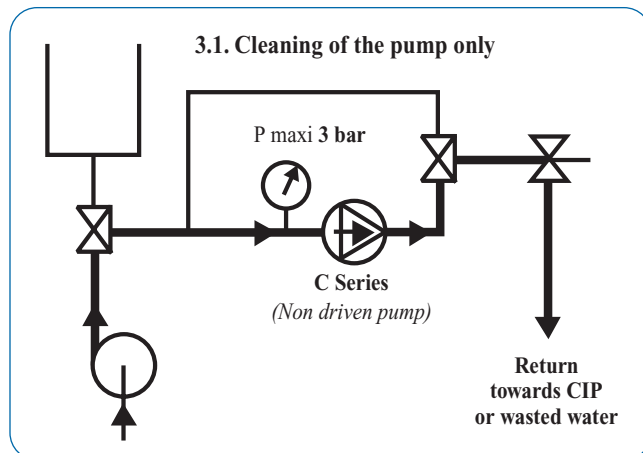

Non driven pump = Pump no driven by the motor but could be driven by the CIP flush.  
Pump stopped = Pump strictly stopped.

## ● Illustrations

Applications : varnish, painting, resin, glue, isocyanate, oil, solvent...



C12i in painting industry

Applications : isocyanate, polyol...



C18a in chemical industry

Applications : ointment, sirup, cream, suppository, shampoo...



C18i in cosmetic/pharmaceutical industry

Applications : flavour, sauce, chocolate, glucose...



C1i-VR in food industry

Applications : yeast, concentrate, glucose, flavour, alcohol...



C4i in beverage industry

Applications : yogurt, ferment, dessert, yolk...



C2i in dairy industry

# SERIE C - Mouvex Technology - Eccentric disc pump

## ◆ Ductile Iron

(Pump equipped with heating base and relief valve)



C Series Pump	C4a	C8a	C12a	C18a	C4a-HT	C8a-HT
Displacement (liters)	0,108	0,178	0,411	0,617	0,108	0,178
Max. flowrate (m³/h)	5	8	12	18	5	8
Max. T° (°C)	100	100	100	100	150	150
Max. pressure (bar)	9	5	9	6	9	6
Max. speed (Rpm)	750	750	500	500	750	750
Particles passage* (mm³)	5	5	15	15	5	5
Opening size (suct/dis) (mm)	50	50	60	60	50	50

\*Pump equipped with flanges (PN16/20)

C Series Pump	A	B	C	D	E	F	G	H	J	K	L	M	N	P
<b>C4a</b>	20	6	233	242	67	254	120	127		150	172	152	4	4
<b>C8a</b>	20	6	233	259	67	254	120	127		150	172	152	4	4
<b>C12a</b>	35	10	310,5	384	109	363	175	12	101	157	239	220	6	6
<b>C18a</b>	35	10	310,5	384	109	363	175	172	101	157	239	220	6	6

C Series Pump	C4a	C8a	C12a	C18a
Port (mm)	50	50	65	65
Weignt (kg)	43	46	115	120

BELOWS : 316 Ti  
 DISC : GS ductile iron  
 CYLINDER : GS ductile iron  
 BODYCASE : GS ductile iron

RINGS : Viton O'Ring  
 Encapsulated teflon  
 FLANGES : PN16, PN20

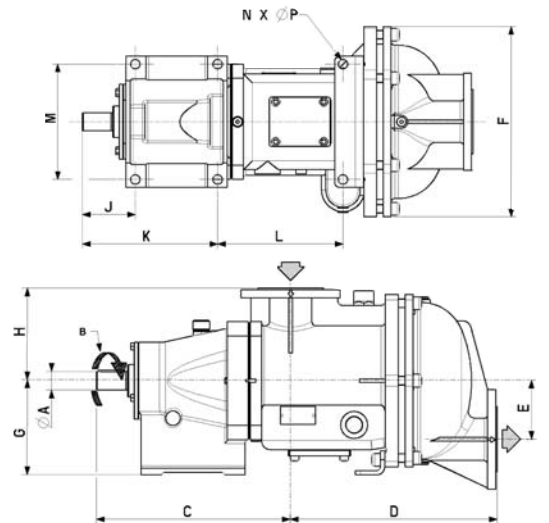
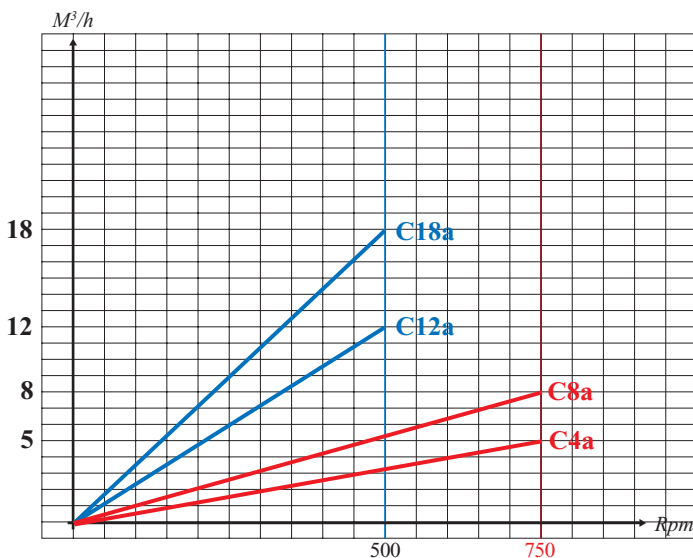

ZI la Plaine des Isles  
 rue des Caillottes  
 89000 AUXERRE - FRANCE  
 T + 33.3.86.49.86.30  
 F + 33.3.86.46.42.10  
 contact@mouvex.com



Distributed by :

Mouvex reserves the right to modify the information and illustrations contained in this document without prior notice. This is a non-contractual document. 01/09  
 Printed in FRANCE by Filigrane  
 © 2009 Mouvex